

FIRST TIME IN HISTORY!

A TWO-WAY MULTI-CELLULAR SPEAKER IN COMPACT FORM

621-385315

THE **DUPLEX** SPEAKER

REVOLUTIONIZES METHODS OF SOUND REPRODUCTION

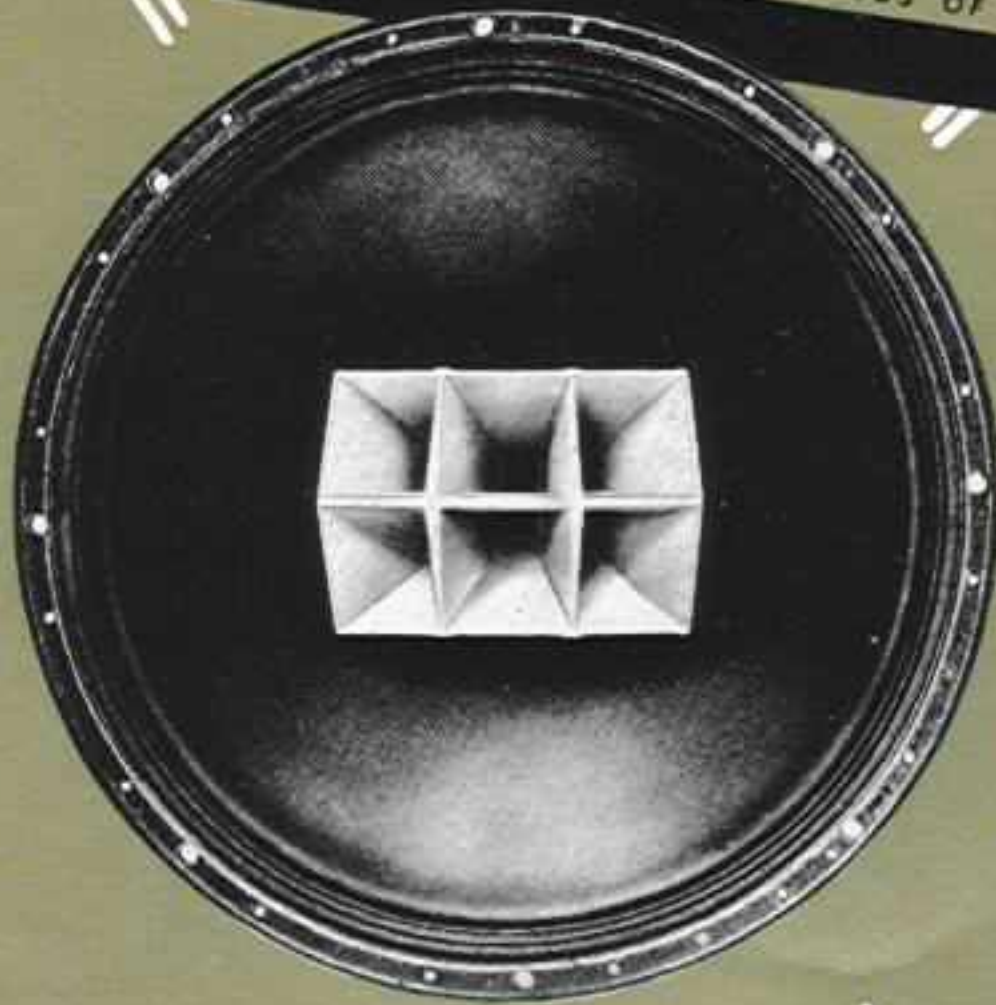

SEP 16 '48

THE **DUPLEX** SPEAKER

Delivers 60° Horizontal Distribution . . .

40° Vertical Distribution . . .

Extremely Low Distortion at All Performance Levels

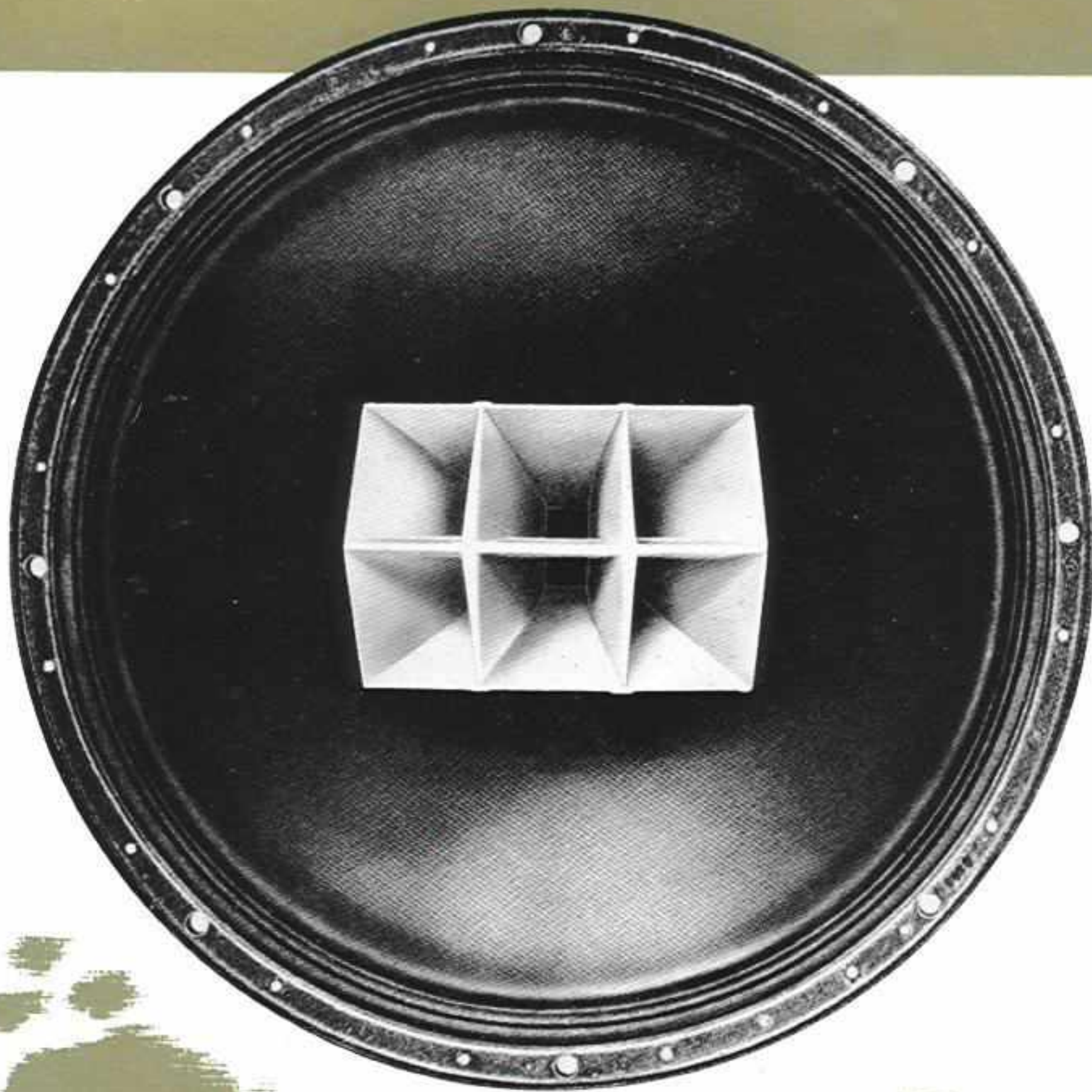

*The Perfect Two-Way Multi-Cellular Speaker for Monitoring,
Radio, Public Address, Recording, Home Radio, Phonograph,
Paging Systems, Television and FM Reproduction*

By combining both high and low frequency units in a compact two-way multi-cellular loudspeaker, Altec Lansing engineers have provided a point source of high quality sound for monitoring, radio, public address and recording. The Duplex speaker, in actual performance, delivers up to 500% greater efficiencies in these operations. The Altec Lansing Duplex speaker delivers the very highest obtainable

quality in home radio, phonograph and F.M. reproduction. Because of its high efficiency and small space requirements, the Duplex provides an ideal sound reinforcement system. Intermodulation effects always produced by single diaphragm type loudspeakers are not heard from the Duplex. It's a new, small, compact two-way loudspeaker that revolutionizes the methods of sound reproduction.

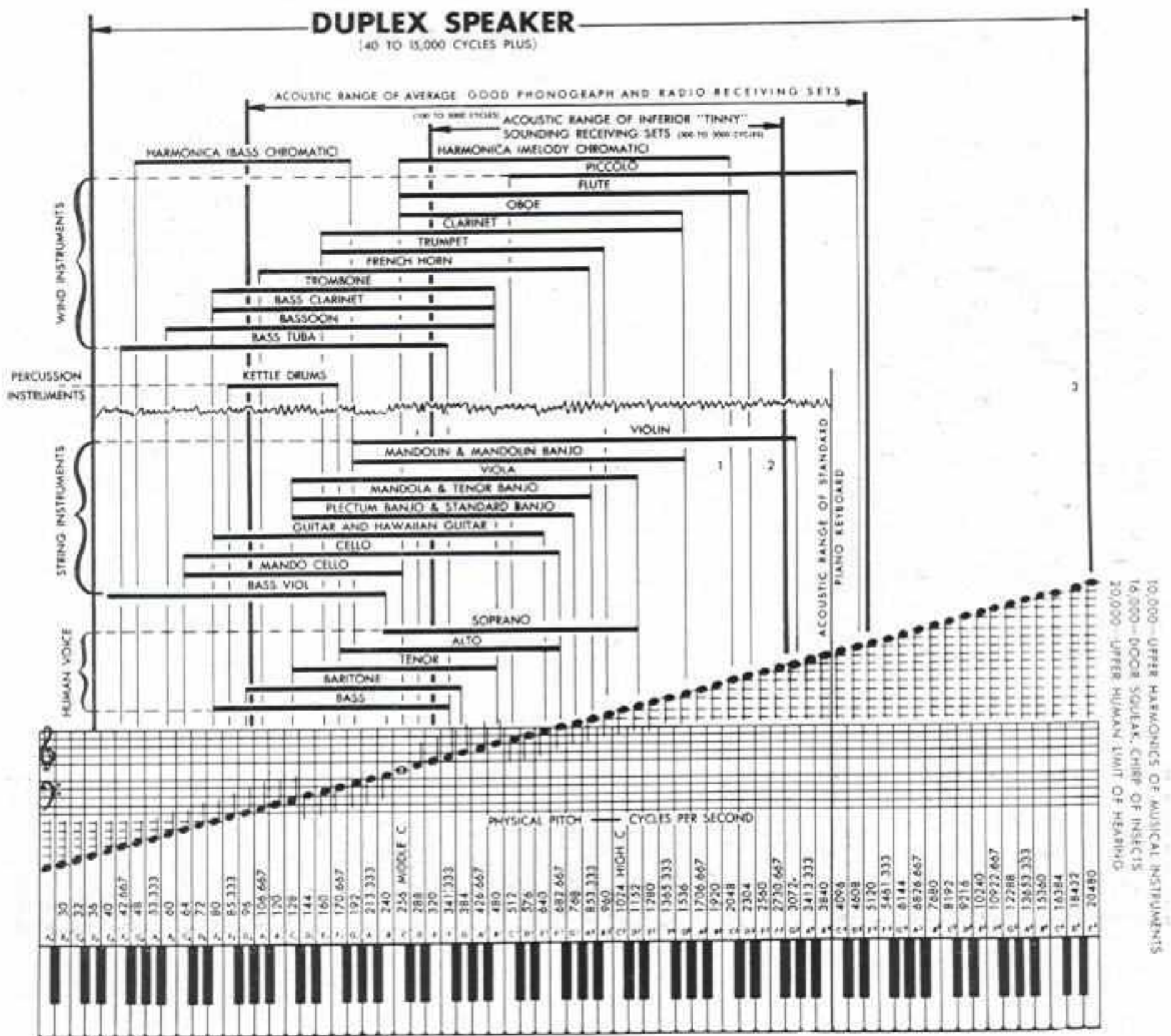

Above is graphically illustrated the amazing frequency coverage of the Altec Lansing Duplex speaker . . . and why it revolutionizes the methods of sound reproduction.



800% INCREASED AREA OF VERTICAL DISTRIBUTION

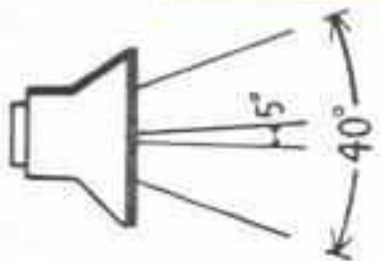

The new amazing Altec Lansing multicellular Duplex Speaker provides up to 800% increased area of quality sound distribution. In the vertical plane, the Du-

plex delivers a forty degree angle of distribution, or eight times the area distribution at high frequencies as compared to single unit speakers of comparable size.

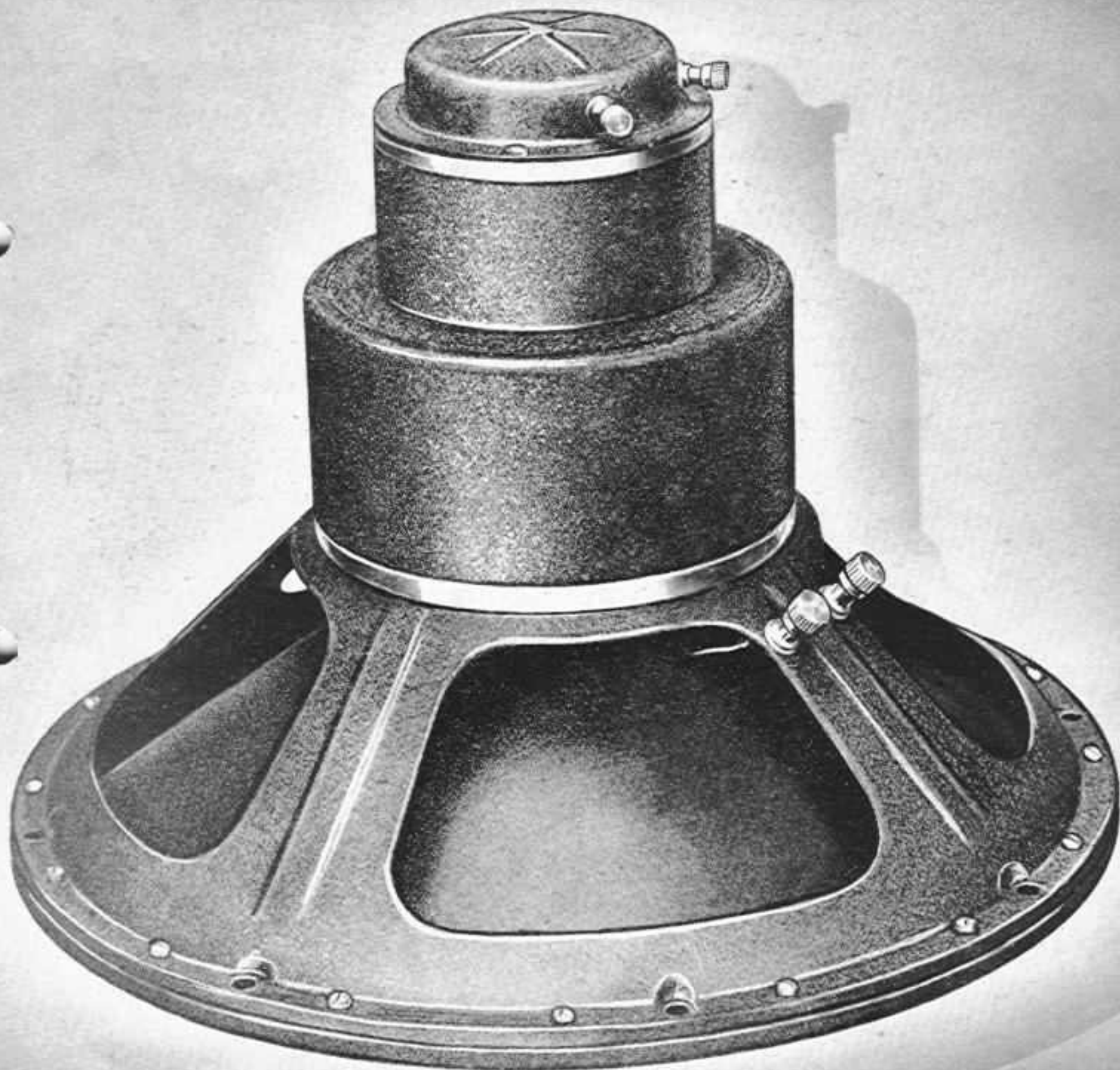

1200% INCREASED AREA OF HORIZONTAL DISTRIBUTION

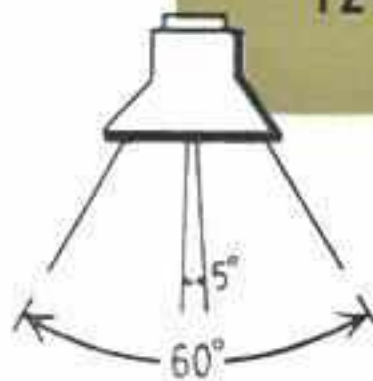

The new amazing Altec Lansing multi-cellular Duplex speaker also provides up to 1200% increased area of quality sound distribution in the horizontal plane. Horizon-

tally the Duplex delivers a sixty degree angle of distribution, or twelve times the area distribution at high frequencies as compared to single unit speakers of comparable size.

DUPLEX SPEAKER SPECIFICATIONS

Area of Horizontal Distribution: 60° • Area of Vertical Distribution: 40° • Low Frequency Cut-off Speaker Mounted in Cabinet: **60 cycles** • High Frequency Cut-off Speaker Mounted in Cabinet: **Above audibility** • Duplex Unit Impedance: **20 OHMS** • Dividing Network Crossover: **2000 cycles** • Dividing Network Impedance: **20 OHMS** • Signal Capacity: **25 watts** • Duplex Speaker Diameter: **15-3 16"** • Duplex Speaker Depth: **11-1 8"** • Shipping Weight Complete Unit in Cabinet: **150 lbs.**



ADDITIONAL ENGINEERING FEATURES OF THE DUPLEX SPEAKER

• One of the most important of many factors contributing to the amazing performance of the Altec Lansing Duplex speaker is the multicellular High Frequency Horn Construction. The voice coil is wound with rectangular aluminum wire and operates in a magnetic field of very high flux density, which is supplied by a recently perfected type of permanent magnet. The aluminum alloy metal diaphragm provides mass stiffness and high velocity of transmission speed. This speed is at least five times greater than through paper cone material normally used for radiating high frequencies. This high frequency unit is designed to operate as a piston up to frequencies above the limit of audibility. The high frequency horn is a multicellular unit having six cells in a 2 x 3 configu-

ration. Each cell covers a 20° solid angle, which means a combined area of distribution in the horizontal plane of 60° and 40° in the vertical plane. The high frequency horn is mounted in the face of the low frequency unit. Power from the high frequency unit is supplied through the pole piece of the low frequency unit. The three-inch voice coil of the low frequency unit is also wound with rectangular wire, and operates in a magnetic field of very high flux density, which is supplied by the newly perfected type of permanent magnet. Both the voice coil construction and the magnetic circuit design aid in delivering a very high efficiency. The low frequency voice coil assembly is mounted in a 15" stiff paper cone resonant at 38 cycles.

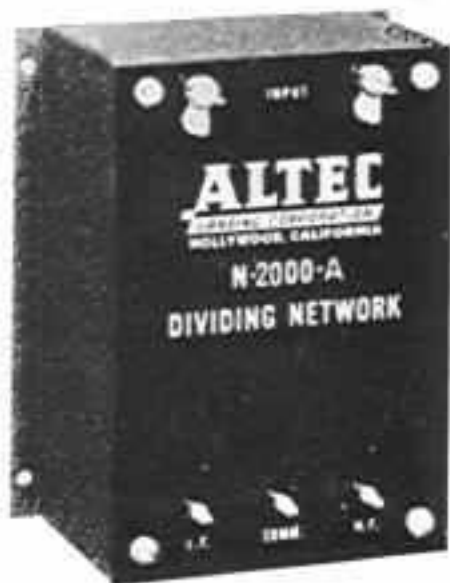

N-2000-A DIVIDING NETWORK

To guarantee perfect practical performance of the Duplex, this dividing network, with a 2000 cycle crossover, has been engineered specifically for and is furnished with the Duplex unit.

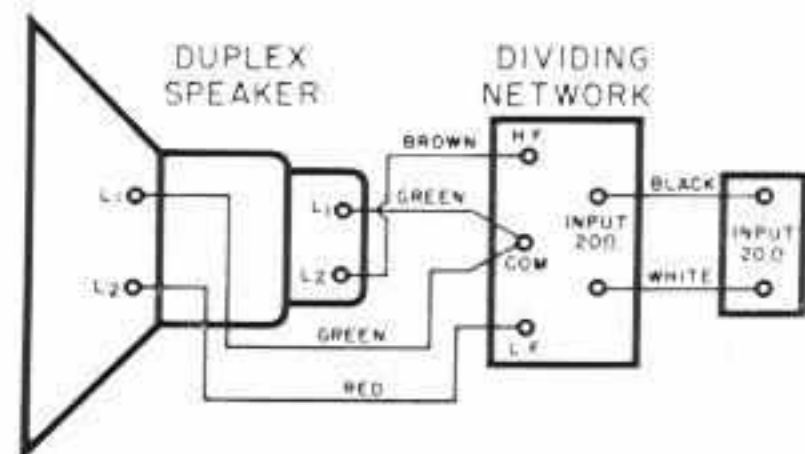

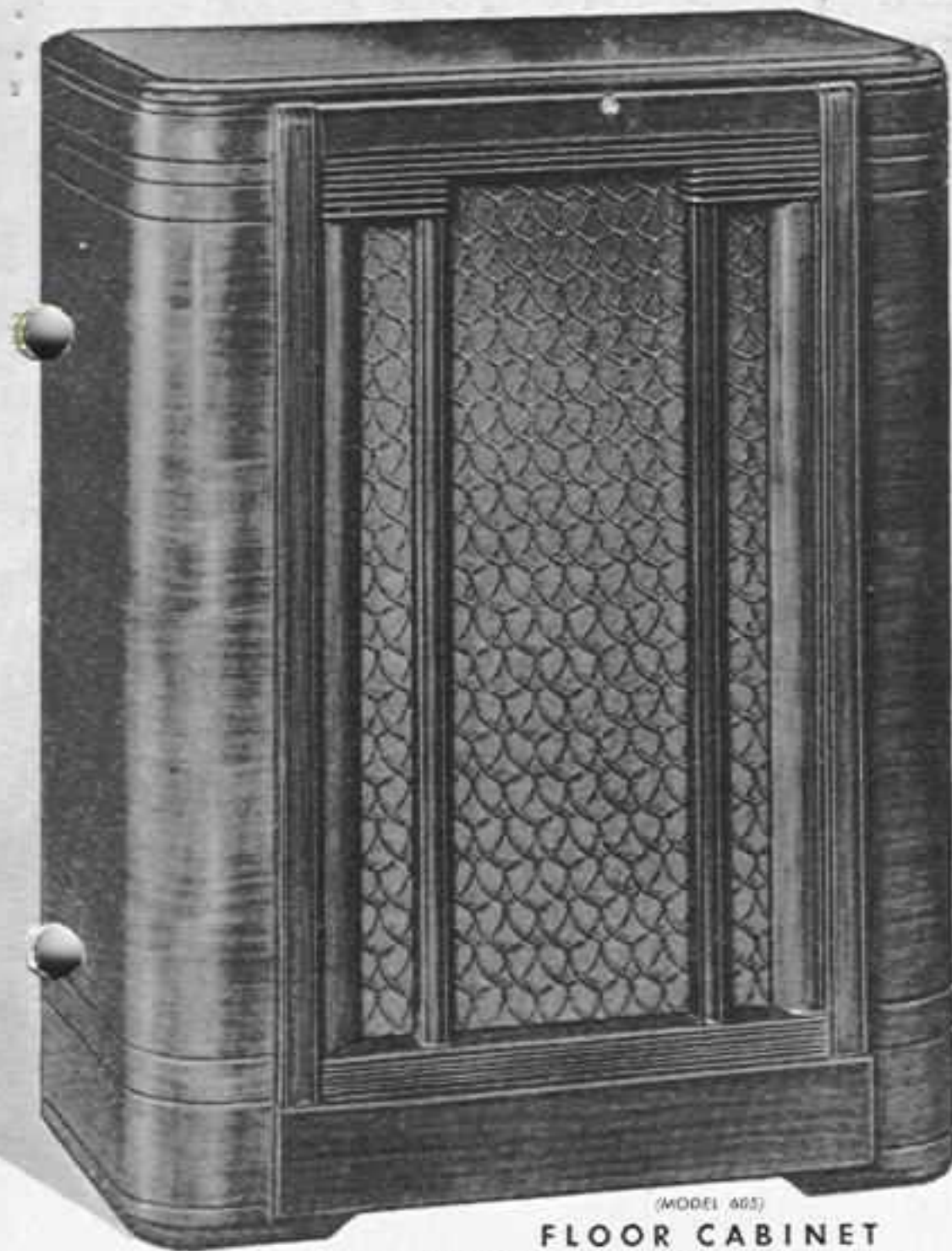

(MODEL 405)
FLOOR CABINET
HEIGHT 38" WIDTH 30" DEPTH 16"

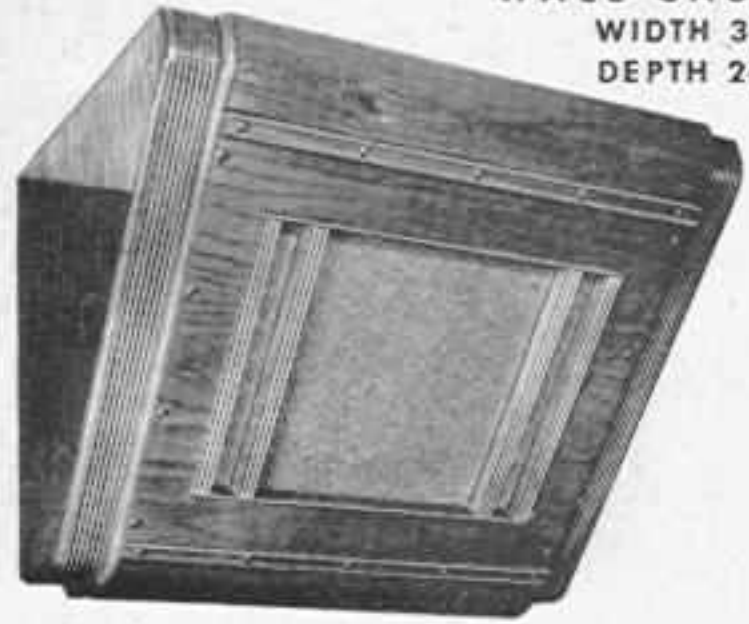

(MODEL 606)
WALL CABINET
WIDTH 34"
DEPTH 24"

UTILITY CABINET
HEIGHT 29½"
WIDTH 25½"
DEPTH 17½"

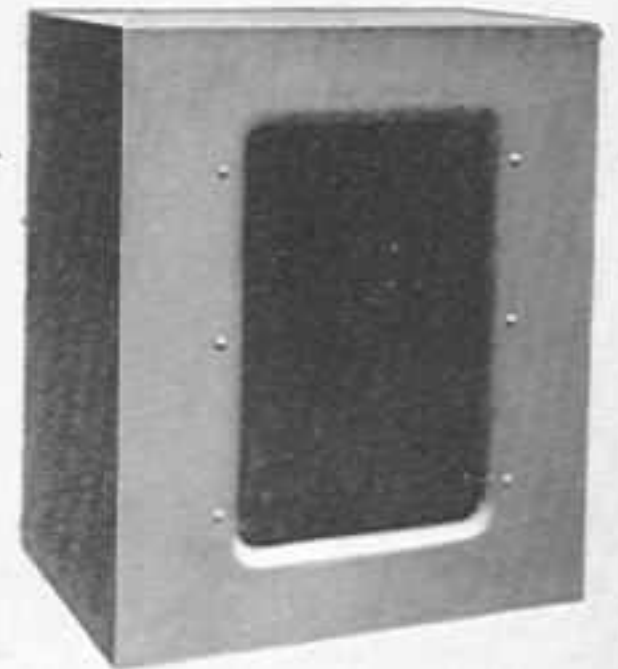

MODERN CABINETS FOR THE **DUPLIX** SPEAKER

Modernly designed floor, wall and corner cabinets are available for varied installations of the Duplex speaker. These cabinets were designed first of all for high quality sound reproduction. They provide ample areas of air space which

permits the Duplex to radiate efficiently to 60 cycles for a wider range of tonal quality. Unobstructed grille fronts permit a full 60 degrees of horizontal distribution. The cabinets are artistically designed and finished in beautiful walnut.